



BEVERAGE-AIR®

Project: _____	AIA#
Item: _____	
Location: _____	SIS#
Approved: _____	

SLATE REACH-IN FREEZER

MODEL:
SF1HC-1S

SF1HC Solid Door Bottom Mount Hydrocarbon Series



2 Year Parts/Labor Warranty
Additional 3 Year Compressor Warranty

CABINET CONSTRUCTION

- Stainless steel door and grille with modern slate finish sides
- Interior features easy to clean white coated steel walls with slate finish interior door
- Electronic temperature control
- LED lighting standard
- Three (3) adjustable epoxy shelves
- Door locks standard
- 6" Casters standard

OPTIONS & ACCESSORIES

- Additional shelves
- 3" Casters and 6" legs

REFRIGERATION SYSTEM

- Uses environmentally friendly, energy efficient R290 refrigerant, and meets all regulatory requirements for CARB, SNAP, DOE & more
- Freezer capable of maintaining product temperature down to 0°F
- Automatic defrost cycle

SF1HC Bottom Mount Reach-In: Slate Series



Please verify qualifying units by visiting, www.energystar.gov/cfs

3779 Champion Blvd., Winston-Salem, NC 27105
1-888-845-9800 Fax: 1-336-245-6453
Beverage-Air.com Sales@bevair.com



BEVERAGE-AIR

MODEL	SF1HC-1S
EXTERNAL DIMENSIONAL DATA	
Width Overall	30 1/4"
Depth Overall	33 1/2"
Height Overall (without casters)	78"
Number of Doors	1
INTERNAL DIMENSIONAL DATA	
NET Capacity (cubic ft.)	23.07
Number of Shelves	3
ELECTRICAL DATA	
Full Load Amperes 120/60/1 NEMA 5-15P	5.0
REFRIGERATION DATA	
Horsepower	1/3
WEIGHT DATA	
Gross Weight	344 lbs
Height - Crated	84"
Width - Crated	32"
Depth - Crated	36"

Bottom Mount Reach-In Solid Door Freezer Model: SF1HC-1S

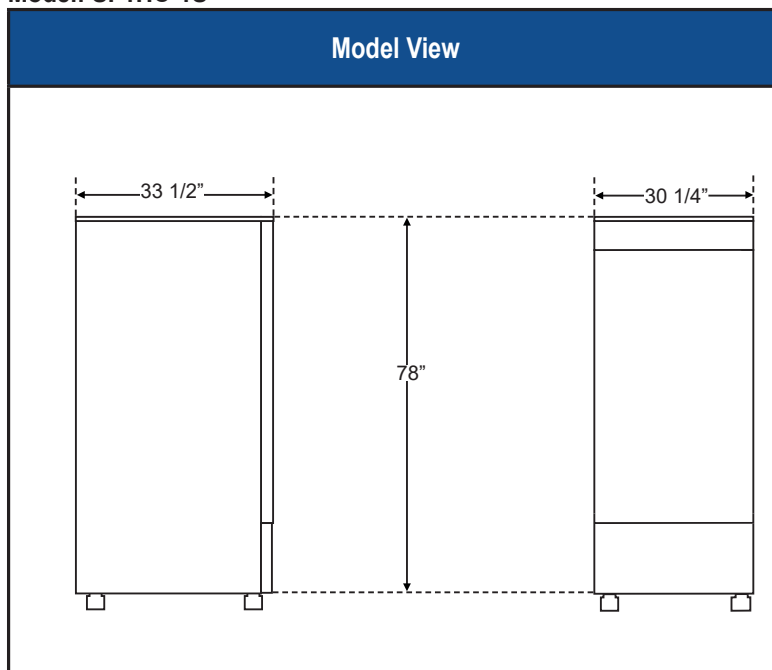

ELECTRICAL CONNECTION



115/60/1
NEMA-5-15P

Units pre-wired at
factory and include 7'
long cord and plug set.



an Ali Group Company



The Spirit of Excellence

3779 Champion Blvd., Winston-Salem, NC 27105
1-888-845-9800 Fax: 1-336-245-6453
Beverage-Air.com Sals@bevalr.com